

# SOFTENER ASSY W/O MEDIA 30x72, 1.5" CE valve

## SET OF EQUIPMENT

- CE 1,5" control valve<sup>1</sup>
- Pressure tank 30x72, 4"<sup>2</sup>
- Brine tank<sup>3</sup>

### <sup>1</sup>CE 1,5" valve assembly (V15CEDT):

- CE 1,5" control valve
- 1,5" meter assembly
- Top stack distributor, insert 50 mm
- Drain fitting 1"
- Power supply
- Injector, DLFC - for Ecomix and cation exchange resin
- Funnel
- Valve instruction manual, Instruction manual

### <sup>2</sup>Pressure tank assembly:

- Pressure tank 30x72, 4"
- Adaptor 4" - 2"
- Riser DN 50 mm
- Connection kit
- Bottom stack distributor TMHL 30, 50 mm solvent

### <sup>3</sup>Brine tank assembly

- Brine tank 30x50, 570 L
- Brine well assembly (brine valve, overflow set)
- Brine grid

## KEY FEATURES

- Ready sets for different filtration medias
- Basic set ready to work with Ecomix and cation exchange resin\*
- Overflow protection of the brine tank
- The set is designed for convenient and quick installation

## CE CONTROL VALVE KEY FEATURES

- Regeneration control by water volume: delayed regen, immediate, both
- Possibility to change the cycle of regeneration stages and their range of time
- Multilanguage menu: English, German, French, Ukrainian
- Different setting modes are available:
  - twin or duplex configurations
  - up to 6 systems to the system controller
  - 2 external devices simultaneously can be connected

## PHYSICAL PARAMETERS

Inlet, outlet	G 1,5"
Drine	G 1"
Brine line	G 3/8"
Operating pressure	2 - 6 bar
Operating temperature	+4...+30 °C
Electrical requirements	230 V, 50 Hz
Electrical power	30 W
Volume of pressure tank	697 L
The volume of the rounded side	80 L
Volume of brine tank	570 L
Dry system weight	110 kg

## Softener assy w/o media, 1.5" CE valve

Code	Product	Water flow rate**	
		Service, m <sup>3</sup> /h (pressure drop 1 bar)	Backwash, m <sup>3</sup> /h (pressure drop 1,7 bar)
RF3072CE15	Softener assy w/o media 30x72, 1.5" CE valve	15,9	11,8

\*For operation with another filter media just need to change the DLFC and injector

\*\*Only for Clack WS1.5 CE control valves includes meter



## ACCESSORIES\*\*

Code	Description
V3017	WS2 Service or Fill Switch Assembly
V3097BSPT	WS1.5" No Hard Water Bypass Male x Female BSPT
V3071BSPT	MAV 1.5 BSPT Revision 2
V3040BSPT-15	WS1.5 Meter Assembly Male x Female NPT 15' Meter Cable

\*\* Not included in the basic set.  
Can installed as additional equipment

## RECOMMENDED MEDIA VOLUME

Code	Description	Volume
ECOMIXA25	Ecomix Type A filter media, 25 L bag	425 L***
ECOMIXC25	Ecomix Type C filter media, 25 L bag	425 L***
ECOMIXP25	Ecomix Type P filter media, 25 L bag	425 L***
HCRSS	Strong acid cation exchange resin HCRS-S	450...500 L
PC002	Strong acid cation exchange resin PC002	450...500 L

The volume of filter material depends on the its characteristics.  
TDS on filter materials can be found on the official website [www.ecosoft.com](http://www.ecosoft.com).  
\*\*\* The amount of Ecomix can be increased by no more than 25 liters

## CONFIGURATIONS

### TWIN



### TWIN ASSEMBLY PARTS

1. RF3072CE15 - 2 pcs.
2. VLV15BSPT - 1 pcs.
3. Filter media<sup>1</sup>

Twin set may operate 2 units with alternative mode (the first unit in operation, the second - in regeneration or stand by) and can produce water during the day at constant flow rate.

### KEY FEATURES

- Ensures stable water quality with constant flow
- User friendly installation
- Doesn't create hydraulic shocks

### DUPLEX



### DUPLEX ASSEMBLY PARTS

1. RF3072CE15 - 2 pcs.
2. DUPLECO15 - 1 pcs.
3. Filter media<sup>1</sup>

Duplex set may operate 2 units parallel and can provide double flow rate during peak consumption.

### KEY FEATURES

- Double flow rate for peak consumption
- User friendly installation
- Doesn't create hydraulic shocks

### 2 - 6 SYSTEMS



### SET FOR 2...6 UNITS WITH CLACK SYSTEM CONTROLLER

1. RF3072CE125 - 2...6 pcs.
2. Filter media<sup>1</sup>
3. WSSYSTCON2\* - 1 pcs.

The Clack system controller may operate 2 - 6 units and has 4 operating modes that ensure efficient operation of the set for various needs.

### KEY FEATURES

- System Controller may operate 2 - 6 units or be used as a water monitor only
- Clack 1.0", 1.25", 1.5" or 2" control valves may be used
- 4 available operating modes: Progressive flow, Alternator, Series, Random

WSSYSTCON2\* - includes a kit for connecting 2 systems. The last number indicates the number of possible connected systems

<sup>1</sup> See "Recommended media volume"

**CONNECTIONS**

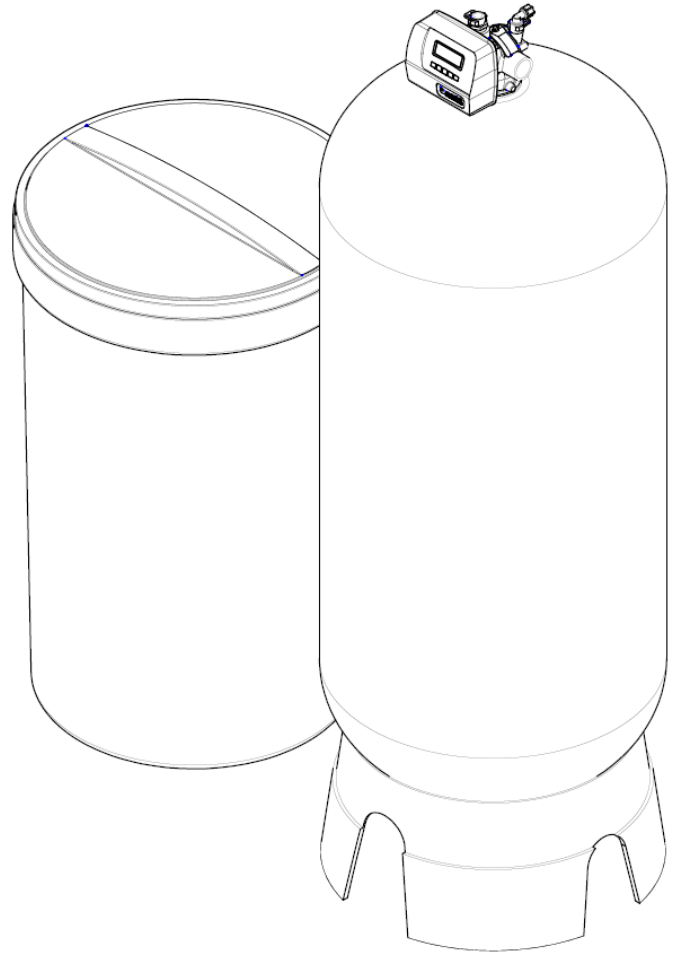
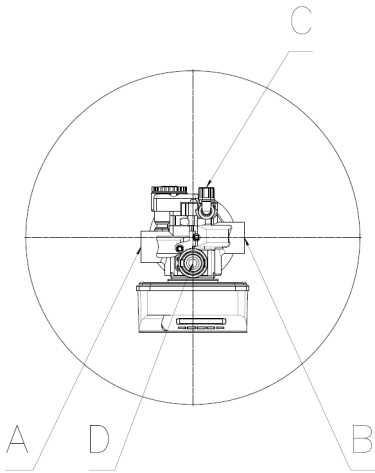

Marking	Nomenclature	Connection	Height
A	Inlet	PH G 1,5"	2160±30
B	Outlet	PH G 1,5"	2160±30
C	Brine line	PH G 3/8"	2250±30
D	Drain	PH G 1"	2370±30

**DIMENSIONS OF SYSTEM**

